

ETERNA always puts quality first during the development. Each product goes through rigorous and meticulous tests. Attention from every tiny detail, every production process, every technology procedure, even the small aspect of product management, is taken very seriously. Because we always uphold the philosophy of manufacturing the highest quality products for our customers.

Eterna is committed to creating folder gluers with the highest quality standards.

Specifications	
Stock Range	
Card board	250-800 g/m ²
Corrugated board	E and F Flute

Power System	
Max. Belt Speed	420 m/min
Jogging Speed	20 m/min
Main Motor	15 kw
Total Power Requirement	22 kw
Max. Air Requirement	0.7 m ³ /min

	650	900	1100
Machine Dimensions	15.8 x 1.35 m	15.8 x 1.5 m	15.8 x 1.8 m
Weight	5.5 Ton	6 Ton	6.5 Ton

* In the interests of product improvement, the manufacturer reserves its rights to change specifications and features without notice.

BOX SIZES

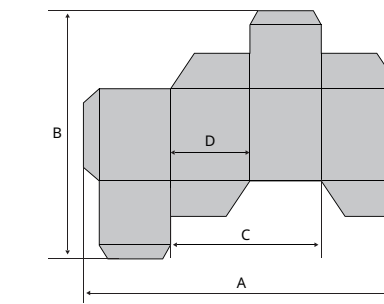

Straight-line boxes (Standard folding section) Unit: mm (inch)

	650	900	1100
A	100-650 (3.94-25.6")	100-850 (3.94-33.46")	100-1100 (3.94-43.31")
B	50-700 (1.97-27.56")	50-900 (1.97-35.43")	50-900 (1.97-35.43")
C	Min 45 (1.77")	Min 45 (1.77")	Min 45 (1.77")
D	Min 10 (0.39")	Min 10 (0.39")	Min 10 (0.39")

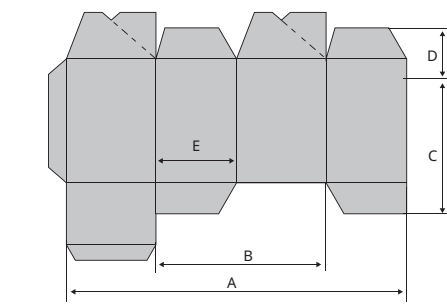

Crash-lock bottom boxes Unit: mm (inch)

	650	900	1100
A	160-650 (6.30-25.6")	160-850 (6.30-33.46")	160-1100 (6.30-43.31")
B	Min 75 (2.95")	Min 75 (2.95")	Min 75 (2.95")
C	60-450 (2.36-17.72")	60-650 (2.36-25.59")	60-650 (2.36-25.59")
D	25-150 (0.98-5.91")	25-150 (0.98-5.91")	25-150 (0.98-5.91")
E	Min 25 (0.98")	Min 25 (0.98")	Min 25 (0.98")

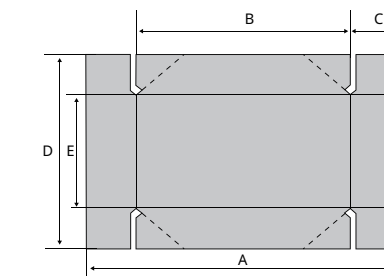

4 corner boxes without lid Unit: mm (inch)

	650	900	1100
A	160-500 (6.30-19.69")	160-700 (6.30-27.56")	160-1000 (6.30-39.37")
B	Min 100 (3.94")	Min 100 (3.94")	Min 100 (3.94")
C	Min 30 (1.18")	Min 30 (1.18")	Min 30 (1.18")
D	Max 600 (23.62")	Max 600 (23.62")	Max 600 (23.62")
E	Min 100 (3.94")	Min 100 (3.94")	Min 100 (3.94")

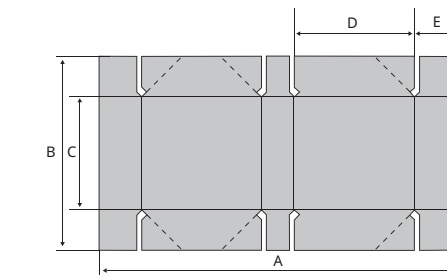

6 corner boxes Unit: mm (inch)

	650	900	1100
A	290-600 (11.42-23.62")	290-850 (11.42-33.46")	290-1100 (11.42-43.30")
B	180-550 (7.09-21.66")	180-550 (7.09-21.66")	180-550 (7.09-21.66")
C	Min 100 (3.94")	Min 100 (3.94")	Min 100 (3.94")
D	Min 100 (3.94")	Min 100 (3.94")	Min 100 (3.94")
E	Min 30 (1.18")	Min 30 (1.18")	Min 30 (1.18")

Automatic Folder Gluer
for Folding Carton

FOLD 650/900/1100

Simply precise

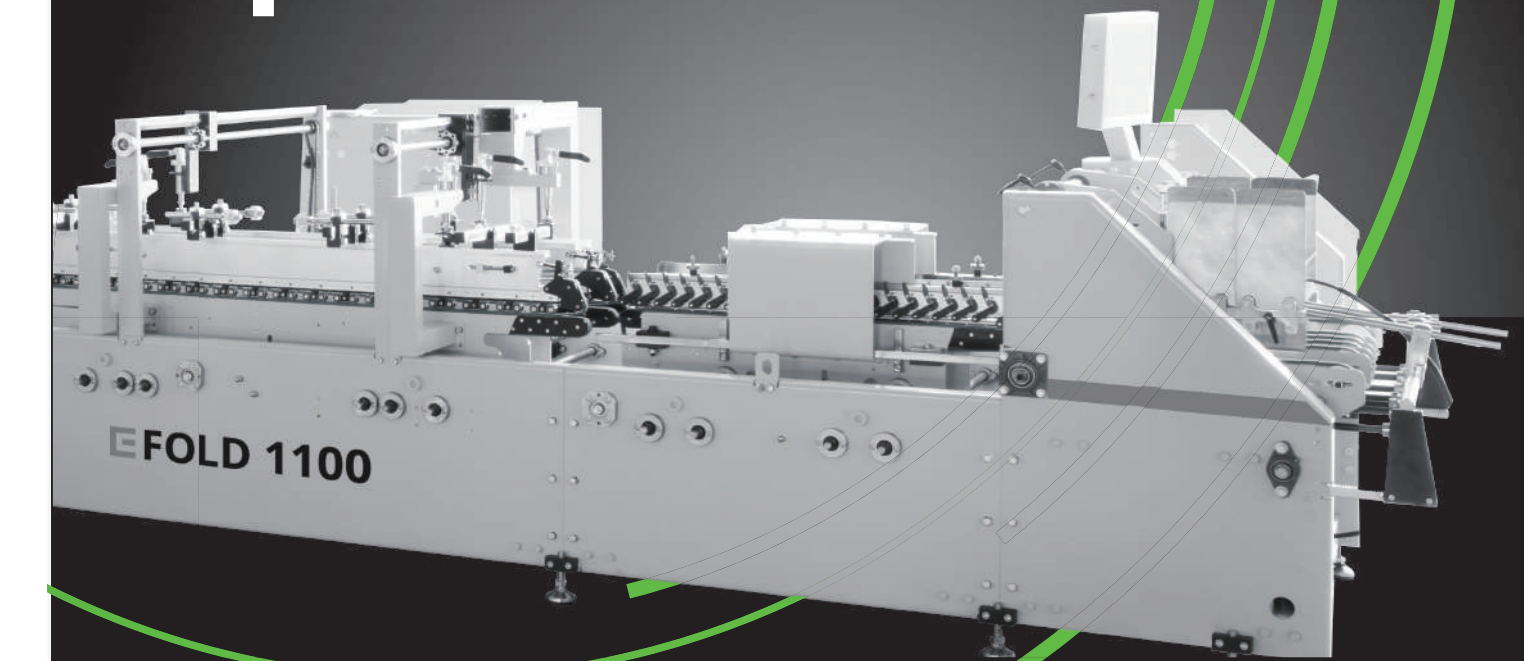

Automatic Folder Gluer
for Folding Carton

E FOLD 650/900/1100

Whether it is a straight-line box, a crash-lock bottom box, a 4/6 corner box or other boxes, you can precisely configure the ETERNA folder gluers according to your production demands.

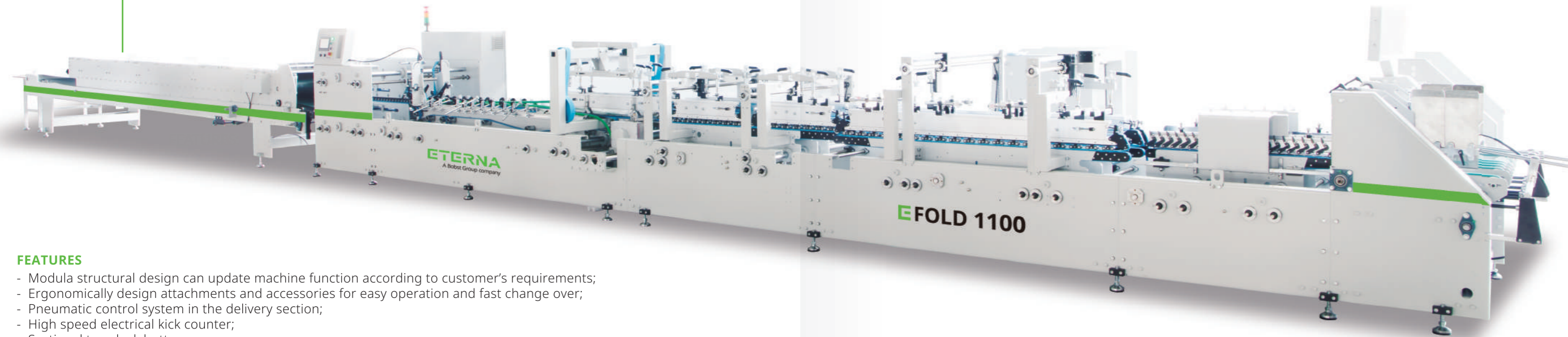

FEATURES

- Modula structural design can update machine function according to customer's requirements;
- Ergonomically design attachments and accessories for easy operation and fast change over;
- Pneumatic control system in the delivery section;
- High speed electrical kick counter;
- Sectional type lock bottom;
- Touch screen HMI control panel.

Configuration

C3

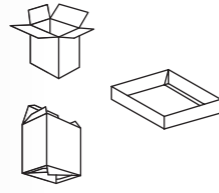

C3 = Straight line boxes, double wall boxes and crash-lock bottom boxes

C6

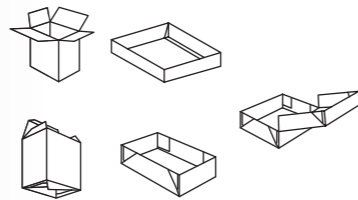

C6 = Straight line boxes, double wall boxes, crash-lock bottom boxes and 4/6 corner boxes.

E FOLD 650/900/1100



FEEDER SECTION

- Designated A/C motor with micro-adjustable variable speed controller for even spacing of box blanks;
- Individual adjustable feed belts (two of which are suction belts) ensure easy setup and smooth feeding;
- Motorized embossing roller guiding the belts to transport sheets.

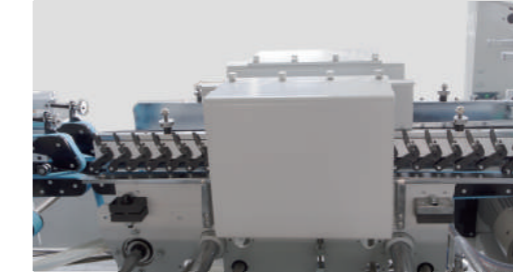

SIDE-ALIGNMENT SECTION

- The side-alignment section guarantees the stability of high speed sheet feeding between the feeder and pre-breaking section.

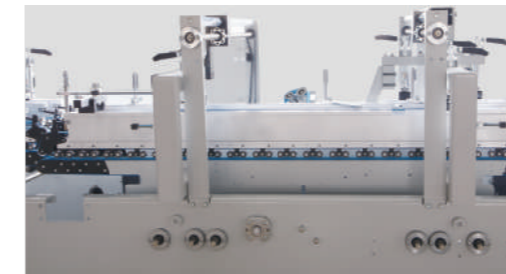

PRE-BREAKING SECTION

- Pre-breaking sword on the left side and belt pre-break device on the right side enable the pre-fold of the 1st and 3rd crease line to make final filling much easier;
- UV grinder and vacuum suction system (optional).



LOCK BOTTOM SECTION

- Three-carrier construction meets diversified folding requirements;
- Sectional upper carriers;
- Easy for mounting lock bottom accessories, more operator friendly;
- Outward folding belt (180°) on the right side, suitable for special boxes.



GLUING SYSTEM

- Two sets of conventional lower gluing pot (left and right side) at final folding section;
- Upper gluing wheel system at lock bottom section can be applied (optional);
- Non-contact gluing system can be applied (optional).

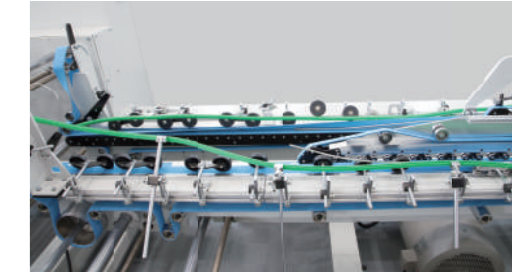

FINAL FOLD SECTION

- Three-carrier construction;
- Left and right outward folding belts speed can be micro adjusted to increase folding accuracy.

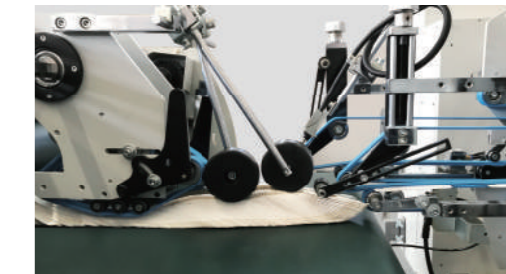

TROMBONE SECTION

- Batch counter kicker or water batch counting system for easy production;
- Jam detector;
- Upper and lower belts can be telescopically adjusted for easy production run.



CONVEYOR COMPRESSION SECTION

- Two operation modes of compressing belt speed;
- Pneumatic pressing system for easy adjustment to increase the gluing effect;
- Either auxiliary conveyor or e-PACK can be applied to improve delivery efficiency (optional).